



STATE OF NORTH CAROLINA
DEPARTMENT OF TRANSPORTATION

ROY COOPER
GOVERNOR

J. ERIC BOYETTE
SECRETARY

March 18, 2021

Contract No.: DL00240
WBS No.: 47860
TIP No.: None
F.A. No.: None
County: Cleveland
Description: Milling, Paving, Islands, Signs & Signals at US 74 Bus. & Castlewood Dr.
Let Date: March 23, 2021

RE: Addendum #1 to Contract DL00240.

To Whom It May Concern:

This letter is to advise all prospective bidders of the following contract changes:

- Plansheet No. 2B-2 has been revised.

Please replace the page 2B-2 of the contract plans with the attached page. Updates will be made to the electronic bidding site to reflect these changes. No pay items will be changed.

To bid electronically you must apply the addendum file which can be downloaded along with the original .ebsx file from the current electronic bidding provider website (bidx.com). To apply the addendum, open the original .ebsx file using the Project Bids Software and select Load Amendment form the File Menu.

Project Bids will not allow the bid to be submitted unless the addendum is acknowledged. Please contact Greg Brittain at 980-552-4222 or at gbrittain@ncdot.gov with any questions.

Mailing Address:
NC DEPARTMENT OF TRANSPORTATION
DIVISION 12
PO BOX 47
SHELBY, NC 28151-0047

Telephone: (980) 552-4200
Fax: (704) 480-5401
Courier: 06-53-03
Website: www.ncdot.gov

Location:
1710 E. MARION STREET
SHELBY, NC 28152

Sincerely,

A handwritten signature in black ink that reads "Mark E. Stafford". The signature is written in a cursive style with a large, stylized initial "M".

Mark E. Stafford, P.E.
Division Engineer

Cc: Larry Carpenter, PE, Division Construction Engineer
Michael Poe, PE, Division Project Development Engineer
Jackie McSwain, Division Team Lead
Blake Guffey, District Engineer

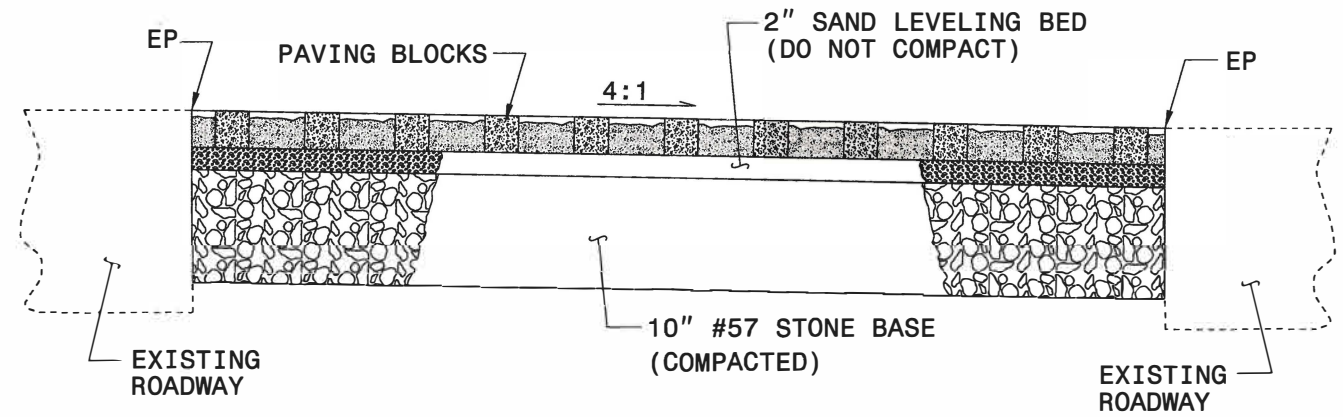
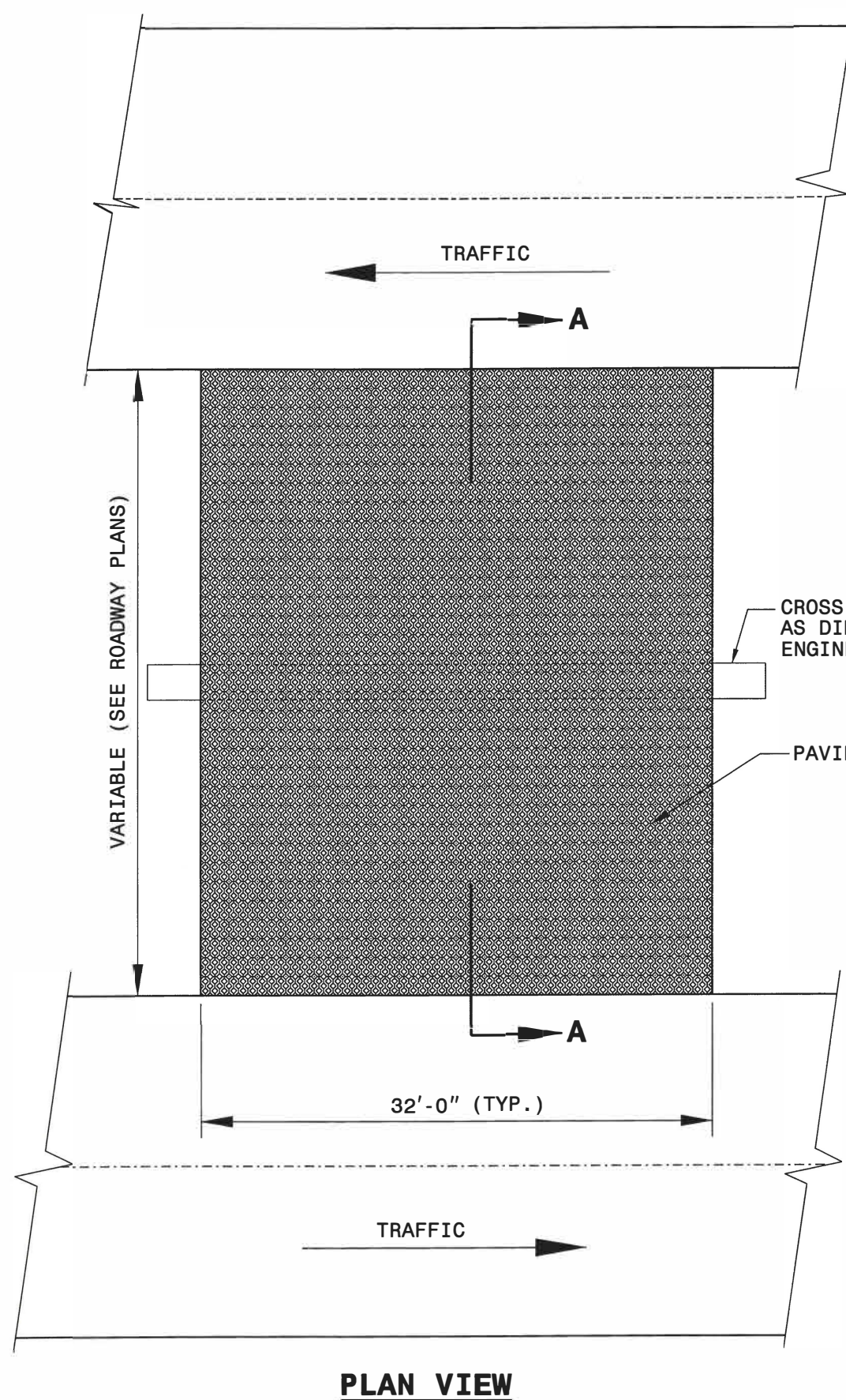

SECTION "A-A"

GENERAL NOTES:
 FILL CORES OF PAVING BLOCKS WITH TOPSOIL
 AND SEED IN ACCORDANCE WITH SPECIFICATION
 SECTION 1660.

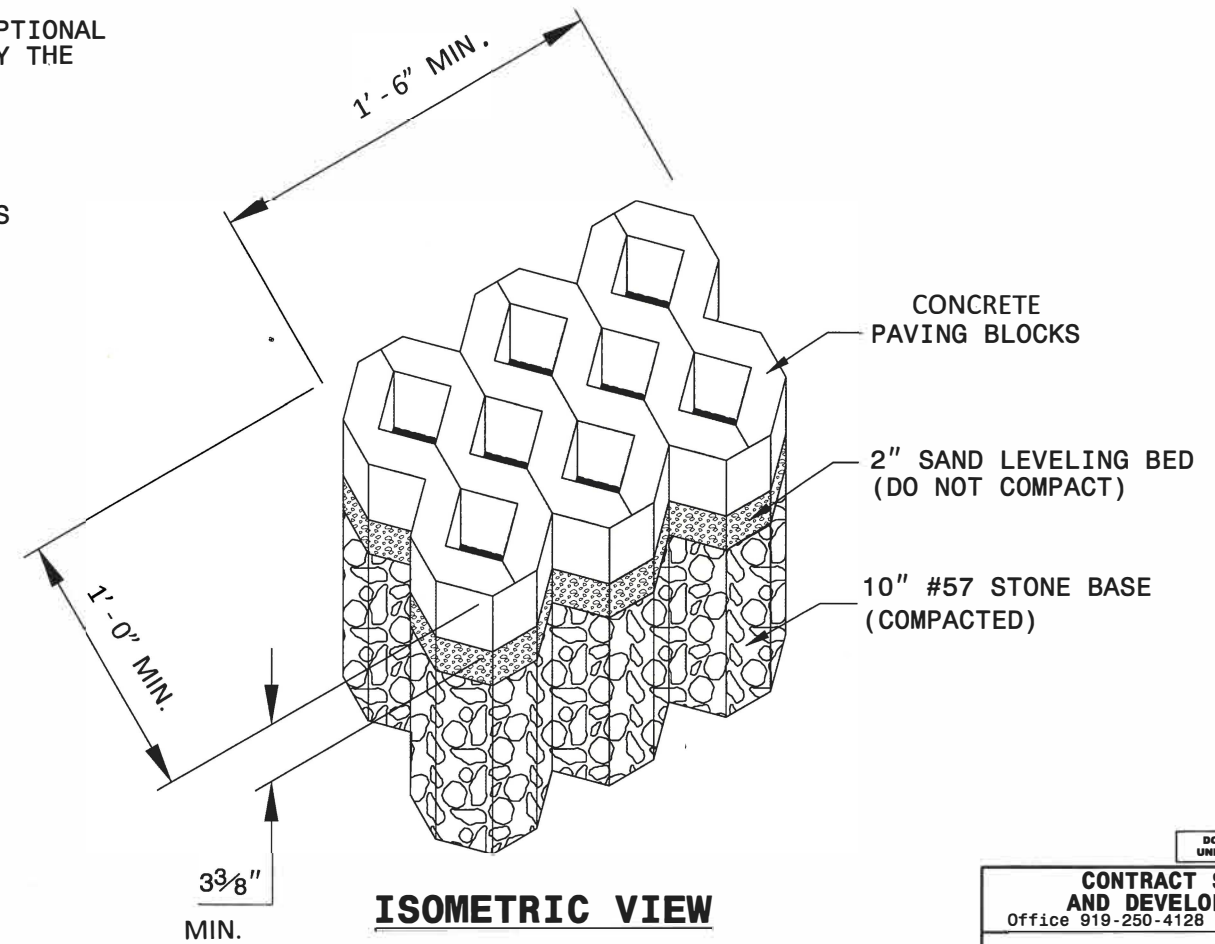

ISOMETRIC VIEW

DOCUMENT NOT CONSIDERED FINAL
 UNLESS ALL SIGNATURES COMPLETED

CONTRACT STANDARDS
 AND DEVELOPMENT UNIT
 Office 919-250-4128 FAX 919-250-4119

**DETAIL FOR
 MEDIAN CROSSOVER**

ORIGINAL BY: C.O. Cuevas DATE: 10-00
 MODIFIED BY: E.E. WARD DATE: 11-03
 CHECKED BY: DATE:
 FILE SPEC.: s:\usr\details\stand\pavingblocks.dgn